

TRYTON[®] 112

Ideal Automatic bar feed system for bar diameters from .039" to .500" for Swiss screw machines and sliding headstock CNC lathes



Fast, Efficient, User-Friendly Operation

The Tryton 112 ensures vibration-free operation due to its rigid, compact construction and unique hydraulic feed and guiding system.

Self-contained and reliable, the totally enclosed guide tubes guarantee maximum RPMs (.500" at 12,000 RPM) and prevent erratic loading of barstock.

The "Combo Barrel" gives superior performance across the total range from .039" to .500" without barrel changes.

Whatever your application, Tryton 112 is the superior bar feed system to enable increased efficiency and reliable production for all types of Swiss screw machines and sliding headstock CNC lathes.

When bar loading simply insert barstock into the back of the barfeed's guide tubes (or front with swingout option) and completely eliminate problems with bent bar jams that commonly occur in gravity loaded magazine bar feed systems.

Swing Out System

An optional swingout system can be added to permit easy front loading and allow convenient access to the machine's spindle.

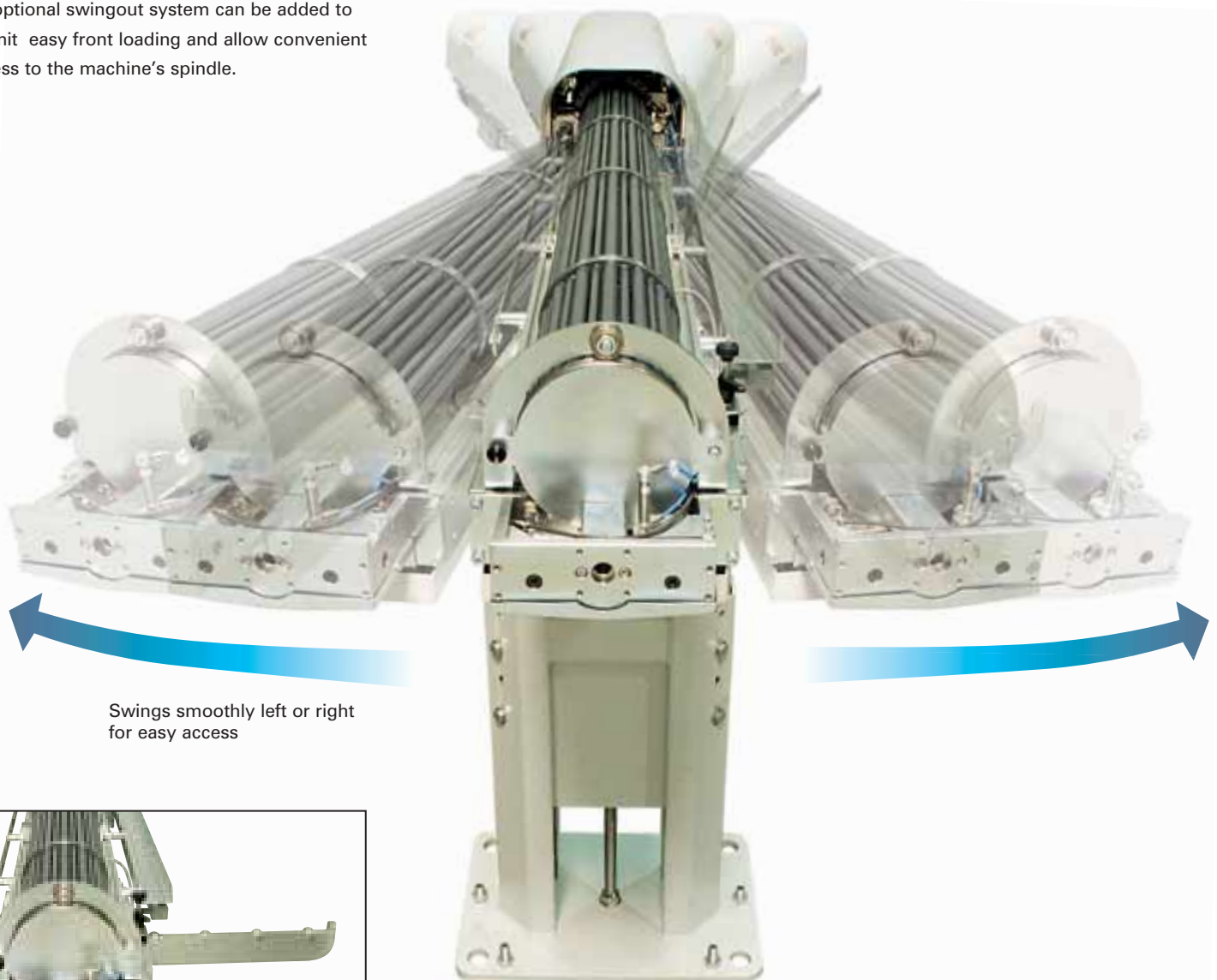

Swings smoothly left or right for easy access

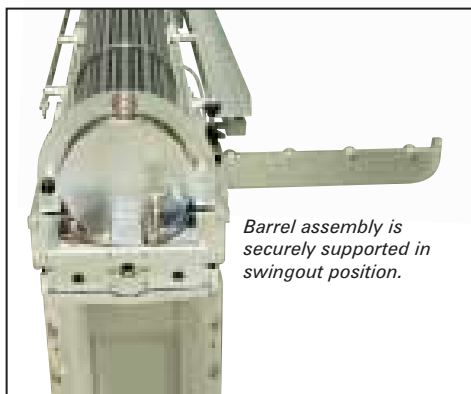

Barrel assembly is securely supported in swingout position.

Speed And Simplicity

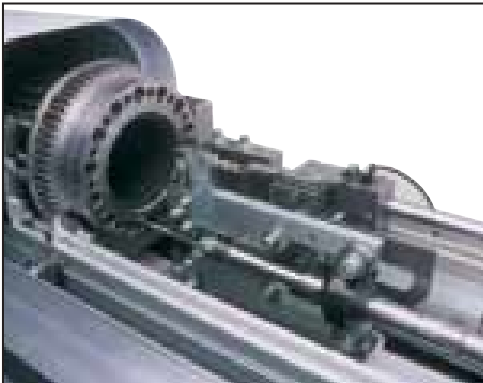

Double check remnant detection device speeds up bar end retraction for continuous production on all bar sizes.



Ergonomic remote control with integrated display simplifies programming and allows freedom of movement around bar feed and machine.

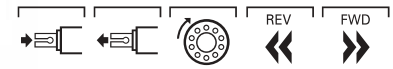

200 icons can be selected to program the Siemens S7 PLC and analyze production.

Combo Barrel Option and Pusher System

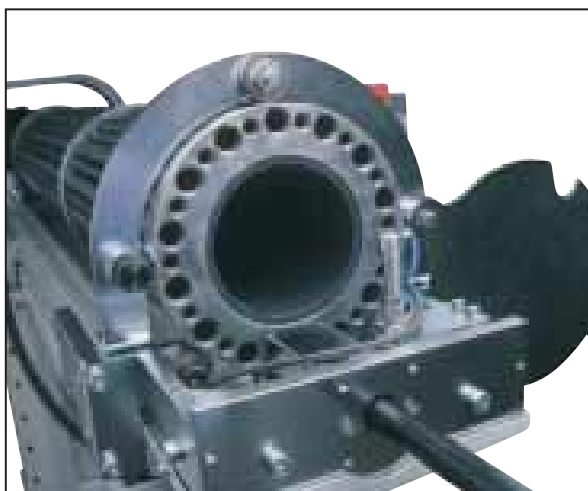

With the "Combo Barrel" you'll get superior performance that covers the total range from .039" to .500" (or .039" to .393" depending on the machine). Its reserve of 14 bars allows hours of uninterrupted, high-performance operation.

The patented hydraulic feeding system supplies constant oil pressure to the tube and the adjustable hydraulic flow and pressure regulator ensures a synchronized head-stock feed rate.

The 112 is ideal for feeding square bars and delicate, small diameter bar stock such as gold and silver.

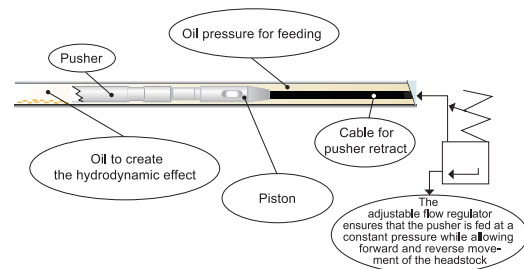

Hydrodynamic Effect

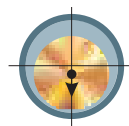

If the spindle speed is zero, the hydrodynamic support is zero and the bar rests on the feed tube.



The revolving bar produces increased oil pressure and the bar is lifted from the bottom of feed tube.

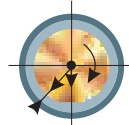

With increasing speed, the hydrodynamic force increases and the bar revolves centrally, ensuring a smooth feed.

The hydrodynamic effect created inside the enclosed tubes gives you vibration-free operation for round or profiled bars

Maximum RPMs of Tryton ensure peak productivity. Speeds may vary depending on application and type of barstock. ▶

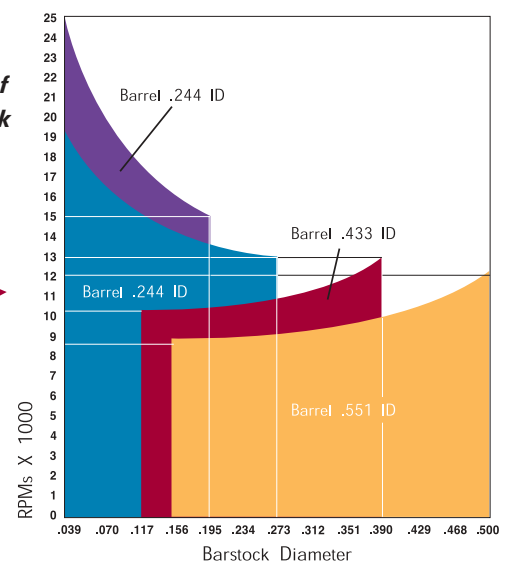

Specifications

Tryton 112 CNC

This bar feed system especially developed for CNC lathes of maximum diameter .500", is equipped with a self-measurement of the top-cut positioning.

Tryton 112 CAM

Bar feed system for Swiss screw machines of maximum diameter .500" and equipped with a spindle interlock so that the first machined part is perfect.

Tryton 107 CAM

Same technical specifications as the TRYTON 112 CAM but for Swiss screw machines of maximum diameter .275". This model is especially designed for the watch and electronic industries.

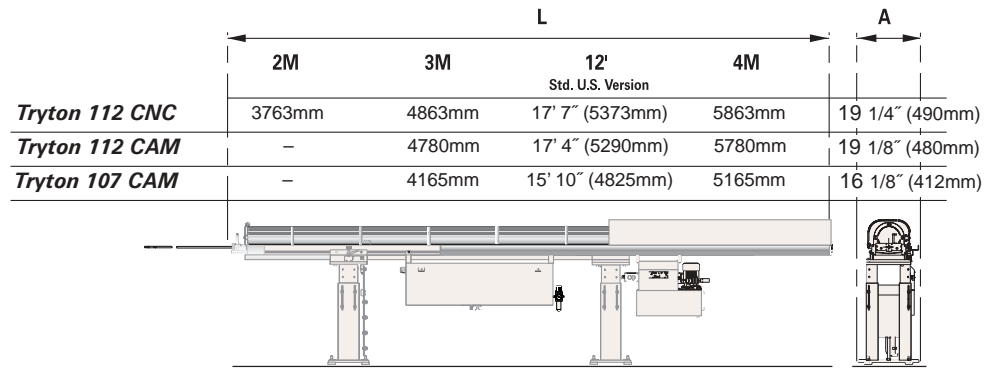

Available Capacities of Barrels

Number of Guide Tubes	Barstock Diameter Range With Preparation	Barstock Diameter Range Without Preparation
45 (6.2mm I.D.)	.039"-.197"	.039"-.156"
36 (8mm I.D.)	.039"-.276"	.039"-.236"
24 (11mm I.D.)	.117"-.393"	.117"-.314"
24 (14mm I.D.)	.156"-.500"	.156"-.393"

Combo Barrel Assembly

28	(14 tubes, 6.2mm I.D.)	.039"-.197"	.039"-.156"
	(14 tubes, 11mm I.D.)	.117"-.393"	.117"-.314"
28	(14 tubes, 8mm I.D.)	.039"-.276"	.039"-.236"
	(14 tubes, 14mm I.D.)	.156"-.500"	.156"-.393"

Unmatched Service and Technical Support

With all LNS systems, you'll benefit from the most knowledgeable service and technical support team in the business.

Our comprehensive sales and support includes:

- Assistance in selecting the right system to meet your specific production requirements
- Application assistance
- Complete installation and training
- Complete inventory of replacement parts
- Worldwide service and technical support



If you can turn it, LNS can feed it

LNS America, Inc. • 4621 East Tech Drive
Cincinnati, OH 45245 • Phone 513-528-5674
Fax 513-528-5733 • E-mail barfeedsales@lnsamerica.com
www.lnsamerica.com